



XN4-V2

Digitally controlled remote strain gauge amplifier

SN: X#####

Texense sensors are designed for data logging. Should the users want to include this sensor in a closed loop system, they must undertake total responsibility from doing so.

Measurement features		
Bridge gauge impedance ⁽¹⁾	350 to 1000	Ω
Max recommended unbalance	350Ω gauge	2
	1000Ω gauge	3.5
		mV
Offset drift with temperature	<10	mV
Gain drift with temperature	<0.2	%
Bridge supply voltage	5	V
Analog output		
Output signal	0 to 5	V
Filter	1 pole filter	
Cut-off frequency at -3dB	Default	90
	On request	Up to 9000
		Hz
Digital communication		
The digital wire Tx/Rx enables to set the following parameters		
Offset	0 to 5	V
Gain	71 to 1270	-
Gain compensation	-2000 to 2000	ppm/°C
Electrical features		
Supply voltage ⁽²⁾	5.5 to 16	V
Supply current (amplifier alone)	3.5	mA
Output impedance	100	Ω
Mechanical features		
Dimensions	14 x 10.5 x 3.6	mm
Material	PCB + Epoxy + stainless steel	
Weight	1	g
Environment		
Accuracy temperature	-20 to +125	°C
Operating temperature	-40 to +125	°C
Storage temperature	-40 to +125	°C
Vibration test	20 Gpp 5'	
Shock	500	G

(1) For 120Ω gauge, please consider XN4-E reference.

(2) For higher supply voltage, please consider XN4-E reference.

Date		Operator	
Customer			
Order			
Product Ref	XN4-V2-##		
SW version	V1.04		

Readings (on a dummy gauge bridge)	
Output at 0mV input	Output at 10mV input
...V	...V

Software setup		
Offset	2.5	V
Gain	200	V/V-
Gain compensation	-340	ppm/°C

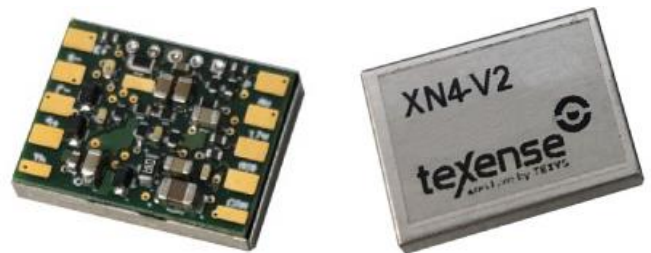

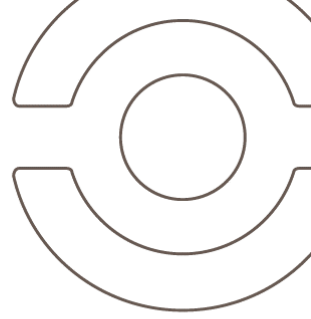

Mechanical drawing

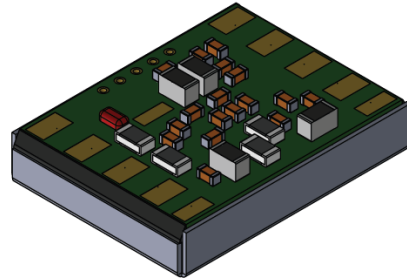
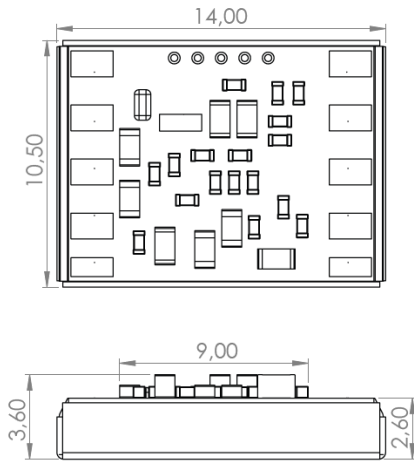

Wiring

There is no need for any balco, nickel, or manganin wires. There is no need for zero or sensitivity adjustment or compensation. The compensation is done on XN4 side.

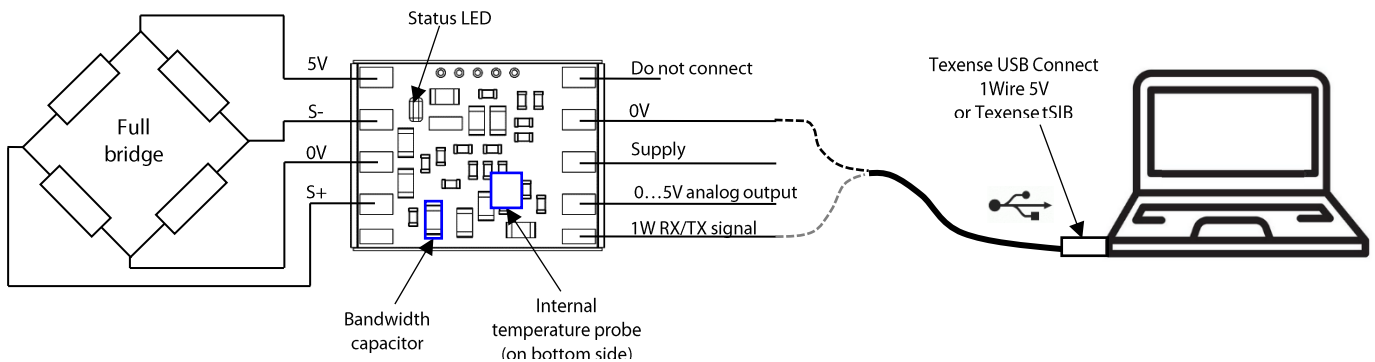

Note: Texense also provides half bridge and quarter bridge versions. For complete information, contact us at info@texense.com

Remote application

In case the gauge bridge is remote from the XN4 amplifier, it is possible to use an external temperature probe close to the gauges to compensate the gauge temperature. The temperature probe is fitted close to the gauges to insure proper compensation. Only use 15kΩ NTC Thermistor (15kΩ at 25°C, Beta = 4000). The external probe is automatically detected if connected and will be considered instead of internal one.

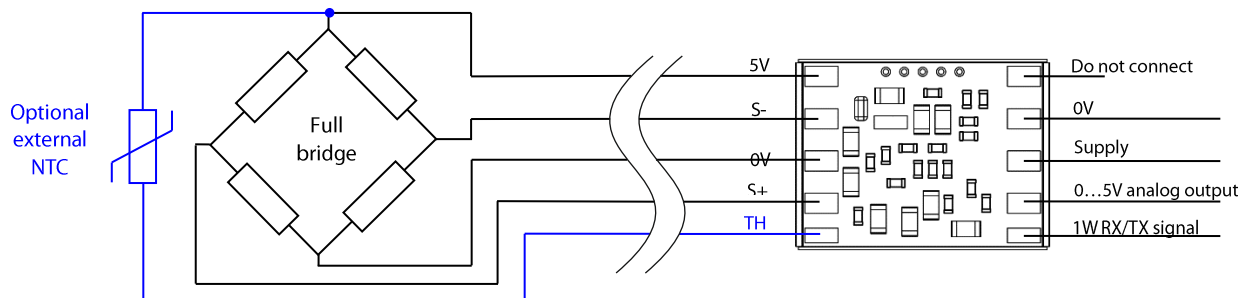

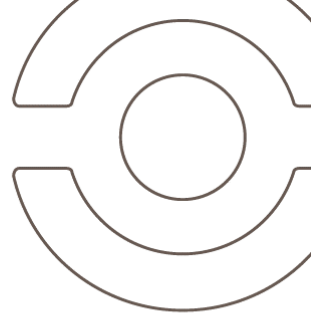

Bandwidth capacitor

The bandwidth can be specified at ordering (see § ordering information) or can be modified by adjusting the bandwidth capacitor. The capacitor value is defined by the formula: $C = \frac{1}{2\pi F_c \times 18000}$. The footprint is 0603, we recommend to use X7R ceramic capacitor.

Examples of capacitor values:

Capacitor	Cut-off frequency -3dB
220nF	40Hz
100nF	90Hz (Default)
47nF	190Hz
1nF	9kHz

Digital offset temperature compensation

To compensate the offset drift, a self-learning procedure is available. This procedure involves to apply a specified temperature ramp in an oven and can be started thanks to the digital communication. See XN4 operating manual for complete information.

Digital gain temperature compensation

To compensate the sensitivity drift, we recommended to use the following parameters:

Material of strain gauged part	Usual coefficient (%/°C)	ppm/°C
Steel (default)	-0.033	-340
Titanium	-0.050	-500
Aluminum	-0.059	-590
No compensation (if XN4 is used with a compensated gauge bridge)	0	0

Digital communication

Drivers

It is necessary to download a VCP driver (Virtual Com Port) FTR232R to convert the USB port in Serial COM Port at the following address: <https://ftdichip.com/drivers/vcp-drivers/>. See information at <https://ftdichip.com/document/installation-guides/>

Software

Use HyperTerminal (for Windows): www.hilgraeve.com/hpte/download.html or Teraterm: <https://tera-term.en.softonic.com/> or any other COM port management software.

Settings

38400 bauds, 8 bits data, no parity, 1 bit stop, no flow control, recommended font Courier New.

See XN4 operating manual for complete information.

Ordering information

Ordering ref:

XN4-V2- Cut-off frequency at -3dB

40: 40Hz
 90: 90Hz (default)
 190: 190Hz
 9000: 9kHz
Other on request

ex: XN4-V2-90