

Motorsport Pressure & Temperature Transmitter VS10V2



Measures and transmits tyre pressure and temperature, provides continuous monitoring of tyres during test, practice and race conditions. Operates with TMS AS Receiver. Installs in a standard 11.3mm valve hole with O-ring seal as a valve replacement, accepts standard valve core. All valve threads conform to ISO 4570:2002

Transmitted data is encrypted and carries a unique serial number ensuring reliable error free data transmission. Each sensor is individually calibrated to a traceable standard, resulting in very high accuracy across the wide operating temperature range (145°C).

Pressure measuring range	0..2.5bar (0..38psi)
Measuring resolution	12mbar (0.18psi)
Pressure accuracy	+/- 1%
Temperature measuring range	10..145°C (50..293°F)
Resolution	1°C
Housing	Al 7075 T6 (Titanium option)
Weight	23g (29g Titanium)
Transmit rate	Adaptive (see text) up to 2Hz
Battery	High-temp Lithium Thionyl cell
Battery Life	>1,500,000 Transmissions
Radio Frequency	433.92MHz
RF Emission category	MPT1340, ETS 300-220
Typical TX range	20m (free space)

Operating modes

- Active mode - When pressure is above 0.17bar (2.5psi) and temperature is above active threshold (typically 40°C). Transmit interval 1sec. (0.5 sec optional)
- Power save mode - When pressure is above 0.17bar (2.5psi) and temperature is below active threshold. Transmit interval 30sec (60 sec optional). If pressure change 25mbar additional transmissions made.
- Sleep Mode - If pressure is below 0.17bar (2.5psi) the sensor makes no transmissions.
- Expected battery life:>1,500,000 transmissions (approx. 500hrs active, 6,000hrs power save, 15,000hrs sleep mode). Battery replacement can be carried out by factory or authorised service agent

Ordering Information:	Order Code	Description
	301200201	TMS Valve sensor 10V2, T6
	301200202	TMS valve sensor 10V2, Ti
	301210101	Battery & Antenna change

Further information: Installation drawing VS10V2
TMS AS Receiver data sheet

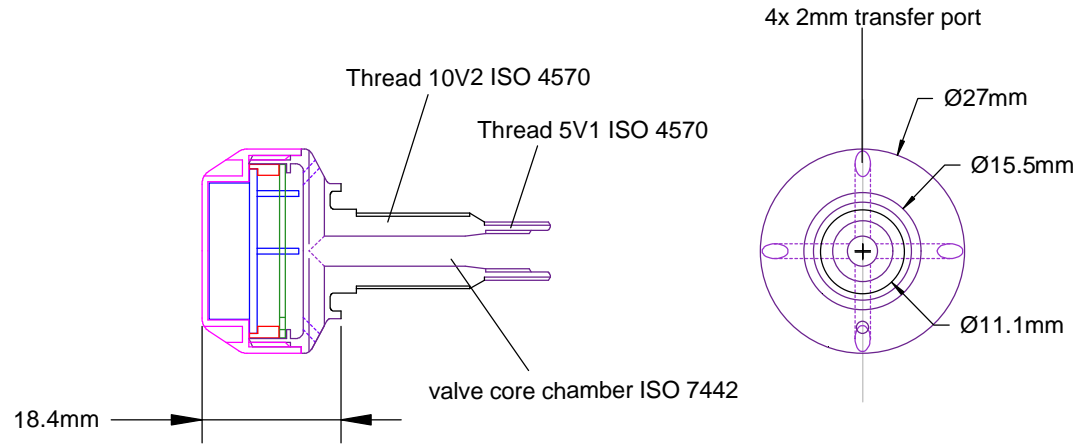

Unit 1, Broomvale Farm
 Little Blakenham, Suffolk IP8 4JU
 Tel. +44 (0)1473 830256
 Fax. +44 (0)1473 830291
 info@brightwater.co.uk

TITLE			
10V2 Wheel Sensor 1-04 Housing base Material - 7075 -T6			
SIZE	CAGE CODE	DWG NO	REV
A4			
SCALE	1:1	04.03.04	SHEET 1 of 1

VALVE HOLE 11.3 H

Light Metal Alloy Rim Tyre Side

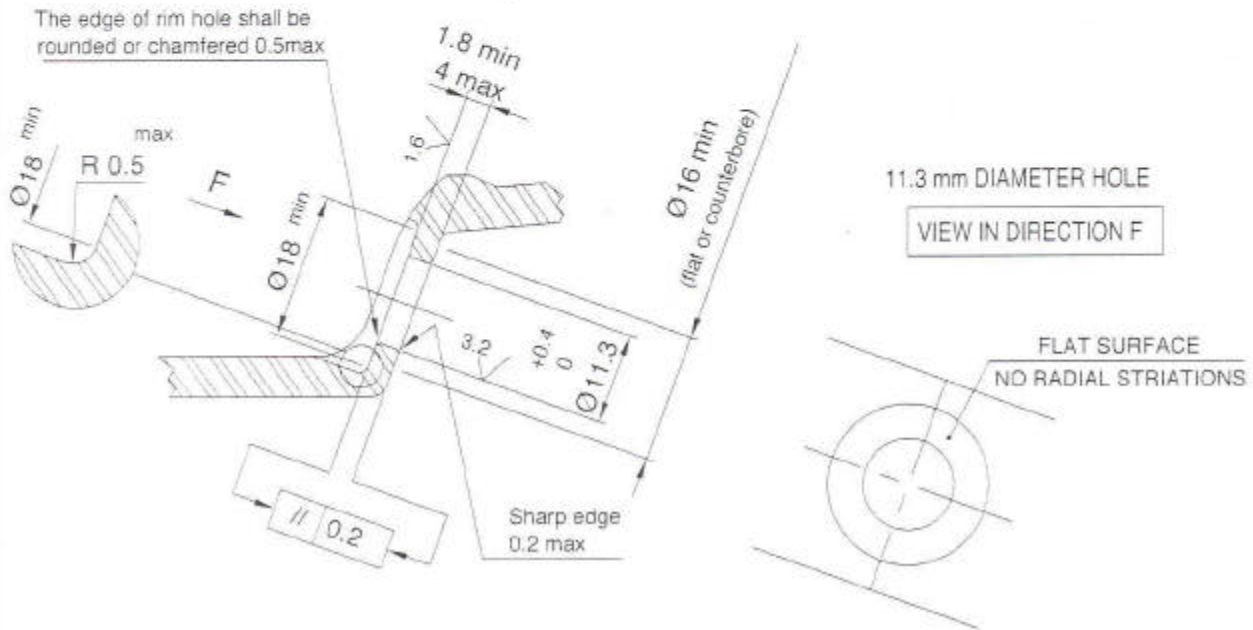

Tyre Side

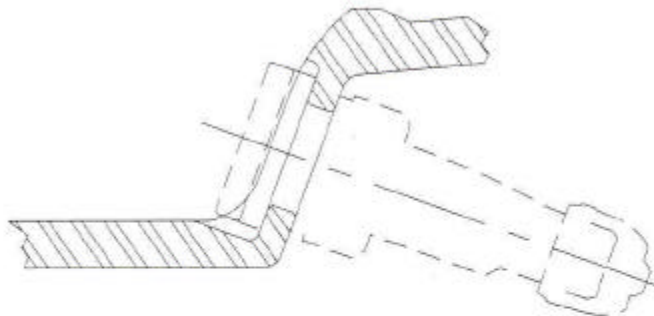

V2.05.1

